

SPINNER® RIDE™ GETTING STARTED GUIDE



Welcome to a **personalized fitness experience** for your members

The Spinner® Ride is a premium bike offering your members a high degree of adjustability, comfort, and performance.

Before you start, learn more about:

- Safety and maintenance included with your bike or visit us at www.precor.com.
- Spinner® Bikes and Spinning® Accessories, Training, and the Spinning® Community at www.spinning.com.
- Precor equipment and the benefits for your members by watching the Cardiovascular Equipment Product Tutorials in the Precor Coaching Center (select languages) at www.precor.com/education.



	Part
1	Seat adjustment pop-pin
2	Seat slider knob



	Part
3	Handlebar adjustment pop-pin
4	Resistance knob

Set up the bike

CAUTION In case of emergency, firmly press down on the resistance knob to stop the flywheel.

Seat Height

Reduce your risk of injury and enjoy a more comfortable ride by adjusting the seat height so that there is a slight bend (25-35 degrees) in your knee at the bottom of a pedal stroke.

To adjust the seat height:

1. Dismount the bike. Turn and pull the seat adjustment pop-pin **1** counterclockwise (-) to loosen and release it from the seat post.
2. Raise or lower the seat to the desired height. Turn the pop-pin clockwise (+) and secure it in a preset hole.

Now adjust the seat's horizontal position so you sit on the bike with the pedals parallel to the floor, and your forward knee is aligned over the center of the pedal.

To adjust the horizontal seat:

1. Dismount the bike. Turn the seat slider knob **2** counterclockwise (-) and move the seat to the desired position. Fully tighten the seat slider knob by turning it clockwise (+).
2. Recheck the seat height to make sure there's a slight bend in your knee.

Handlebar Height

The handlebar should be approximately the same height as the seat, or higher if you feel back discomfort.

To adjust the handlebar height:

1. Turn the handlebar adjustment pop-pin **3** counterclockwise (-) to loosen and release it from the post.
2. Raise or lower the handlebars to the desired height, then secure the pop-pin in a preset hole.
3. Turn the handlebar adjustment pop-pin clockwise (+) to fully tighten it.

Foot Position

Place the balls of your feet securely in the toe straps so that the balls are on the center of the pedals.

Foot Strap

Adjust the toe straps to hold your foot firmly on the pedal, allowing you to apply force throughout every part of the pedal stroke.

Note If your foot comes loose when riding, firmly press down on the resistance knob to stop and secure your foot.

Resistance Control and Stop Function

Turn the resistance knob **4** to change the pedaling resistance. Press down on the knob to stop the flywheel and pedals.

- To increase or decrease resistance, turn the knob clockwise (+) or counterclockwise (-).
- To stop the flywheel and pedals from moving, firmly press down on the resistance knob to bring the flywheel and pedals to a stop.

Ride the bike

CAUTION Before beginning any fitness program, see your physician for a thorough medical exam.

Ask your physician for the appropriate target heart rate for your fitness level.

Failure to follow these safety instructions can result in serious personal injury.

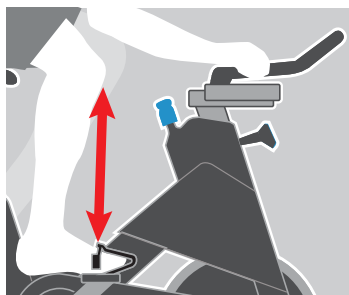

Step 1: Set up the bike so that the seat, handlebar, toe strap, or toe clips are properly adjusted for your height and comfort.

Important Make sure that all pop-pins are engaged and fully tightened after adjusting your bike.

When you sit on the bike with the pedals parallel to the floor, your forward knee should be aligned over the center of the pedal.



Step 2: Mount the bike and secure your shoes in the toe straps or toe clips.

Turn the resistance knob clockwise (+) to gradually increase the tension. To vary the intensity of your workout, adjust the knob while riding.

Step 3: To dismount, firmly press down on the resistance knob. Do not dismount the bike until the pedals and flywheel have come to a complete stop.

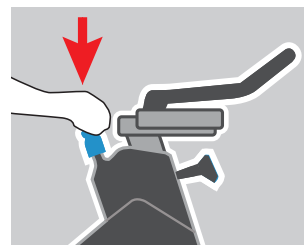

After each workout

For commercial bikes:

- Release all tension from the resistance knob after each use to allow for perspiration to evaporate. If bikes are used in a class setting, the instructor should direct class participants to release all tension from the resistance knob after each use.

For bikes used in a home setting:

- Wipe down the bike after each use. Pay special attention to wipe under the resistance knob. When done, turn the resistance knob clockwise (+) to put tension on the flywheel so that the pedals do not rotate freely.
- When the bike is not in use, always keep some resistance on the flywheel.

Spinner® Ride™ Assembly Guide

To assemble the Spinner® Ride, follow the steps in the order listed in this assembly guide. For more product information, visit us at www.precor.com.

WARNING At least two people are required to assemble the equipment.
DO NOT attempt assembly by yourself.

Assembly Requirements

When assembling the bike, we recommend you:

- Assemble the equipment close to where you plan to use it.
- Assemble the equipment on a solid, flat surface, so that it remains level and stable.
- Leave a minimum of 0.5 m (19.7 in.) on at least one side of the bike and 0.5 m (19.7 in.) behind or in front of the bike.

Hardware Kit

	Component	Quantity
1	Socket head bolt (M8 x 20 mm)	4
2	Flat washer (8 mm)	4
3	Socket head bolt (M3 x 8 mm)	4
4	Socket head bolt (M8 x 16 mm)	2
5	Socket head flat bolt (M8 x 16 mm)	2
6	Socket head set screw (M8 x 16 mm)	1

	Component	Quantity
7	Seat slider end cap	1
8	2.5 mm hex key	1
9	4 mm hex key	1
10	5 mm hex key	1
11	6 mm hex key	1
12	8 mm hex key	1

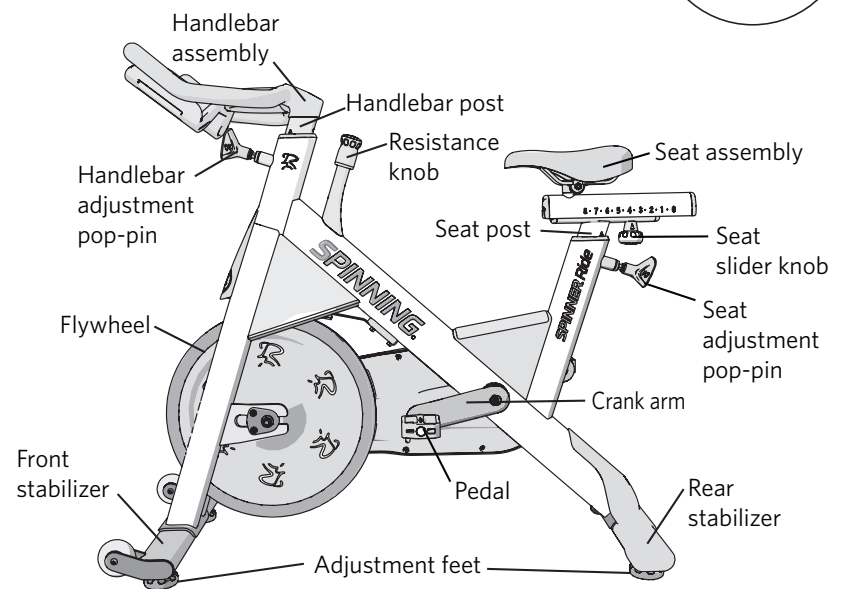

Begin Assembly

Remove the following parts from the packaging: handlebar assembly, hardware kit, stabilizers, product documentation, seat assembly, and spare parts.

CAUTION Damage to the bike during assembly is not covered by the Precor Limited Warranty.
During assembly, you must protect the handlebar and seat adjustment pop-pins from damage.

To attach the rear stabilizer:

1. Stand the bike frame on its front end (toward flywheel) and place a piece of foam under the bike frame (Figure 1) to protect the handlebar adjustment pop-pin from damage.
2. Attach the rear stabilizer to the frame using two bolts 1 and two washers 2 (Figure 2). Using a hex key 11, tighten to 15.6 ft-lb (21.2 N-m).

To attach the front stabilizer:

1. Stand the bike frame on its back end and place a piece of foam under the bike frame (Figure 3) to protect the seat adjustment pop-pin from damage.
2. Attach the front stabilizer to the frame using two bolts 1 and two washers 2 (Figure 4). Using a hex key 11, tighten the bolts to 15.6 ft-lb (21.2 N-m).
3. Return the bike to the upright position.

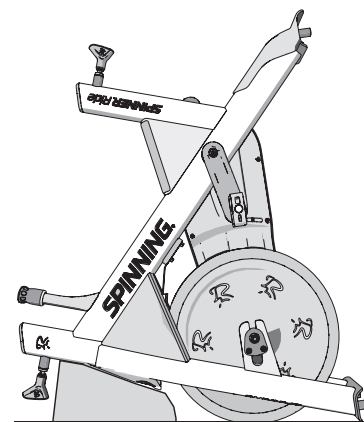

Figure 1

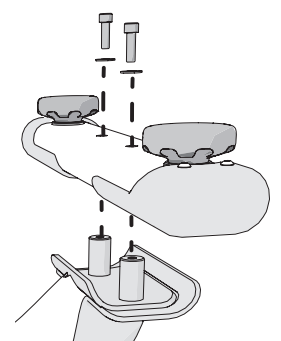

Figure 2

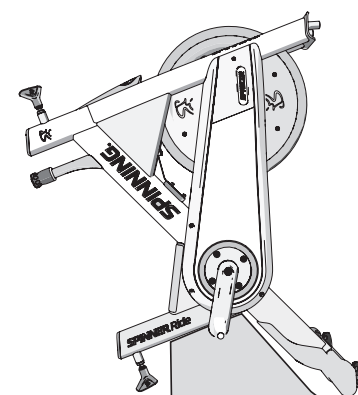

Figure 3

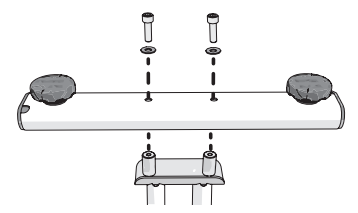

Figure 4

To attach the seat assembly:

1. Slide the seat assembly onto the seat post (Figure 5).
2. Insert one bolt ③ into the underside of the seat slider and fully tighten it to set the travel limit (Figure 6).
3. Attach the seat slider end cap ⑦ using three bolts ③ (Figure 7) and fully tighten with a hex key ⑧.

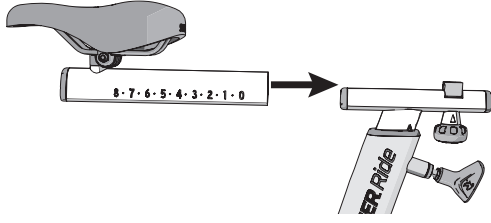

Figure 5

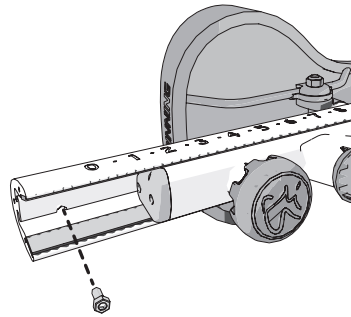

Figure 6

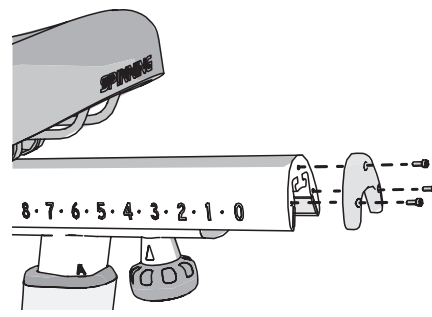

Figure 7

To attach the handlebar assembly:

1. Position the handlebar post onto the handlebar assembly (Figure 8). Attach it using two bolts ⑤ and tighten them with a hex key ⑩.
2. Insert a set screw ⑥ into the opposite side of the handlebar post (Figure 9) and tighten it using a hex key ⑨.
3. Pull out the handlebar adjustment pop-pin and slide the handlebar post into the bike frame (Figure 10). Release the pop-pin to lock the handlebar post into place.

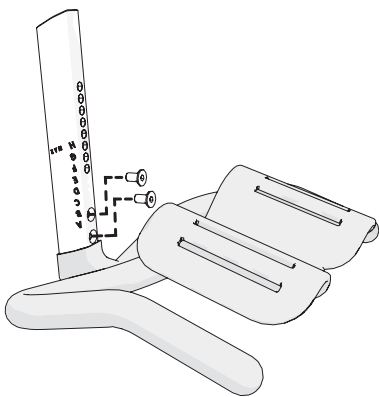

Figure 8



Figure 9

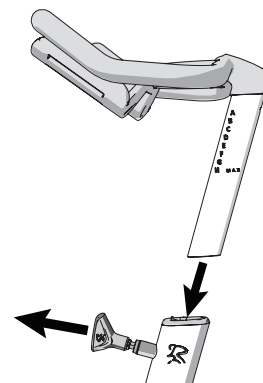

Figure 10

Attach the Pedals

Hold the pedals with the toe straps facing forward.

To attach the pedals:

1. Insert a pedal into its corresponding crank arm (Figure 11).
2. Use a rubber mallet to lightly tap the center of the pedal into the crank arm to seat it (Figure 11).
3. Secure the pedal using one bolt ④ (Figure 12) and torque to 33 ft-lb (45 N-m) with a hex key ⑫.
4. Repeat Steps 1-3 to attach the other pedal.

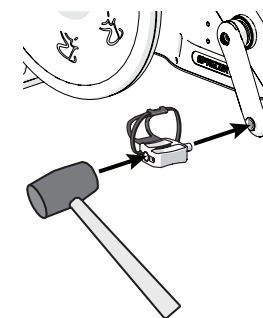

Figure 11

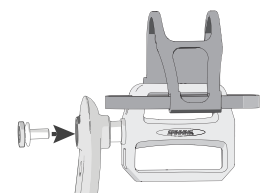

Figure 12

Level the Bike

Important Place the equipment on a flat surface. Rotating the adjustable feet does not compensate for extremely uneven surfaces. Make sure the bike is level before allowing anyone to use it.

To level the bike:

1. Try to rock the bike. If there is any movement, tip the bike to one side to locate the adjustable feet (Figure 13).
2. Correct the height of each adjustable foot by turning it clockwise (+) to lower the bike, or counterclockwise (-) to raise the bike.
3. When you are finished leveling the bike, recheck for movement and readjust as necessary.

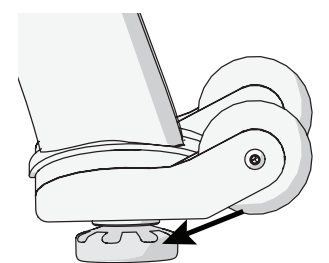

Figure 13

Bike Assembly Checklist

Use this checklist to make sure your bike is assembled properly.

- Check that all bolts are tightened to proper torque specification and no parts are missing.
- Check that the seat post moves freely and locks in different positions.
- Check that the seat is level and does not rotate or tilt. Tighten and adjust as needed.
- Test the seat for movement front to rear.
- Brake tension is adjustable by turning the resistance knob in the front of the seat. Pressing down on the knob will apply the brake if you need to stop quickly.
- Pedal the bike at a moderate pace and test the resistance knob for smooth resistance changes.
- Press down on the knob to ensure the bike stops quickly.

Once testing is complete, tip the bike forward using the handlebars and roll it on a smooth surface to its final use location. If required, level the bike.

Bike Maintenance

Before you begin

- Precor recommends owners implement a thorough maintenance program that incorporates regular safety inspections by qualified maintenance technicians as outlined in this Maintenance Guide (“Guide”). Also, Precor recommends that technicians thoroughly read and understand the safety guidelines and maintenance procedures covered in this Guide.
- This Guide provides information about items that need to be inspected and maintained on a daily, weekly, and monthly basis.
- During maintenance, place an “Out Of Order” sign on the bike.

Important *It is the duty of the owner to maintain equipment in accordance with the instructions in this material and any accompanying material.*

Always purchase replacement parts and hardware from Precor. If you use parts not approved by Precor, you could void the Precor Limited Warranty. Use of parts not approved by Precor may cause injury.

Recommended Tools

- Standard set of hex keys

General Care

- Never use abrasive cleaning liquids or petroleum-based solvents on the bike. Use a soft nylon scrub brush to clean grooves and textured surfaces on pedals.
- **For commercial bikes:**
 - Release all tension from the resistance knob after each use to allow for perspiration to evaporate. If bikes are used in a class setting, the instructor should direct class participants to release all tension from the resistance knob after each use.
- **For bikes used in a home setting:**
 - Wipe down the bike after each use. Pay special attention to wipe under the resistance knob. When done, turn the resistance knob clockwise (+) to put tension on the flywheel so that the pedals do not rotate freely.
 - When the bike is not in use, always keep some resistance on the flywheel.
- Clean all surfaces of the frame and plastic components. **Keep excess moisture away from electronic components and dry completely with a lint-free cloth to prevent electrical shock or damage.**
- After the first ten hours of use and every 100 hours of use thereafter, re-torque the pedals to 33 ft-lb (45 N-m).
- If your facility allows members to interchange pedals, check all pedals after each class to ensure pedals are properly secured to prevent damage to them, which may lead to injuries.

Daily Maintenance Tasks

Note Raise seat and handlebar posts to their highest setting to expose moisture.

- If your facility allows members to interchange pedals, check all pedals after each class to ensure pedals are properly secured to prevent damage, which may lead to injuries.
- Wipe the bike frame using a clean lint-free cloth dampened with 30 parts water to 1 part non-abrasive detergent.
- Use a lint-free cloth to dry the bike. Pay special attention to the handlebar, pop-pins, resistance knob, chain guard, flywheel, and seat adjustment assembly.
- Check warning and instruction labels.

Weekly Maintenance Tasks

- Clean the floor under the equipment. Do not lift and hold equipment while vacuuming.
- Ride each bike to identify any vibration, noises, and chain issues. Most vibration issues are caused by poor flywheel alignment or a loose chain.
- Check for flywheel alignment.
- Inspect each bike for loose assemblies, parts, bolts and nuts. Give particular attention to the following:
 - Frame hardware
 - Seat and handlebar hardware including knobs and pop-pin handles
 - Toe straps/toe clips

Monthly Maintenance Tasks

The monthly maintenance check is a comprehensive inspection of the entire bike frame and hardware in addition to the weekly maintenance tasks. Inspect the bike for rust or corrosion. Turn the bike upside down to thoroughly examine the underside components.

- Check flywheel alignment and torque flywheel nuts as necessary.
- Remove chain guard and check for loose chain/belt. Adjust chain/belt as necessary.
- Use a soft nylon scrub brush to remove rust build-up in small crevasses, such as pedals and pop-pin threaded stems.
- Inspect all wear items for adjustments or possible part replacement. Give particular attention to the following:
 - Inspect brake pad for wear. Excessive wear, such as glazing or leather separation, indicates replacement is required.
 - Inspect seat pads for wear. Rips, tears, or excessive movement indicates replacement is required.
 - Tighten seat hardware.
 - Inspect pedals for excessive movement. Excessive movement indicates replacement is required.
 - Tighten pedal toe straps and toe clips.
 - Inspect and tighten resistance knob assembly.
 - Level feet.

- Clean and seal the bike frame.
Sweat can corrode the bike frame. Precor recommends that you seal the bike frame at least once a month.

To seal the bike frame:

1. Wipe the bike frame using a clean lint-free cloth dampened with 30 parts water to 1 part non-abrasive detergent.
2. Rinse the bike frame using a clean lint-free cloth and dampened with water only. Dry completely with another clean lint-free cloth.
3. Seal the bike frame using wax or a polish to repel sweat and liquids. For best results, apply the wax or polish per manufacturer’s instructions.

Replacement Parts

Depending on the use and maintenance of the product, certain items can be replaced on a schedule. The list below shows the components that can be replaced on a schedule to keep the bike in top working order.

Part	Replacement Schedule
Brake Pad Assembly	1 year
Chain	2 years
Belt	2 years
Pedal	2 years

Adjust the Chain

Important *Improper chain adjustment will cause premature wear and may void the Precor Limited Warranty.*

Insert a screwdriver into the chain tension inspection window and gently move the chain up and down (Figure 1). A properly fitted chain should travel ½-inch up and down. If the chain is too loose or too tight, adjust the chain.

To adjust the chain:

1. Loosen the bolt and remove the cover window (Figure 2).
2. Loosen the axle nuts ① on the chain adjustment screws (Figure 3) on both sides of the bike.
3. Tighten or loosen both chain adjustment nuts ② equally on both sides of the bike.
4. Slowly turn the crank arm and adjust the chain tension so the chain falls smoothly onto the sprockets.
5. Align the chain to the sprockets by adjusting the angle of the flywheel so the chain runs smoothly over the teeth of the sprockets.
6. Replace the cover window.

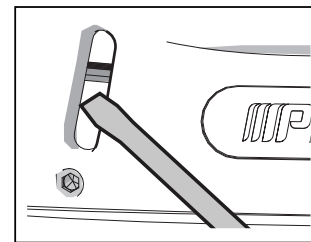

Figure 1

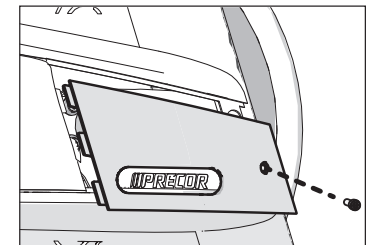

Figure 2

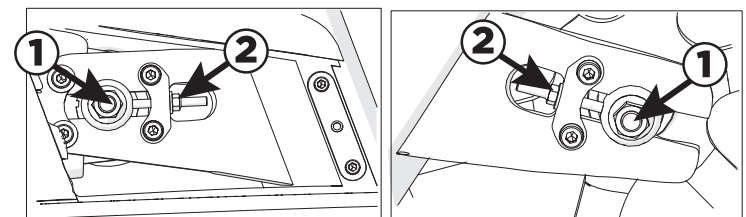

Figure 3

Adjust the Belt

Important Improper belt adjustment will cause premature wear and may void the Precor Limited Warranty.

To adjust the belt:

1. Loosen the bolt and remove the cover window (Figure 2).
2. Loosen the four bolts holding on the cover and remove it (Figure 4).
3. Remove the four bolts holding on the back cover and remove it (Figure 5).
4. Turn the nut to adjust the belt to between 140-150 pounds of tension (Figure 6).

Important If the belt is stretched beyond adjustment, replacement of the belt is recommended.

5. Check that the belt moves smoothly by slowly turning the crank arm while keeping your fingers away from the belt.
6. Replace the covers.

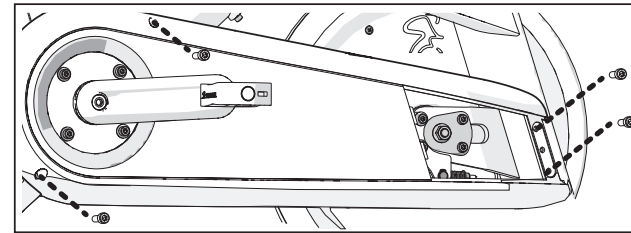

Figure 4

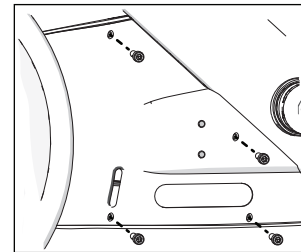

Figure 5

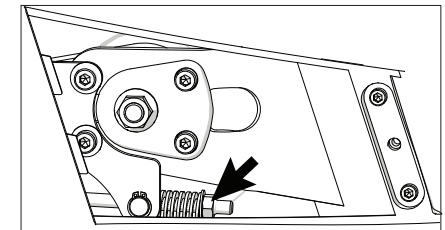

Figure 6

Replace the Brake Pad

Your bike comes with a spare brake pad. To order more pads, contact Precor Customer Support.

To replace the brake pad:

1. Remove tension from the brake pad by turning the resistance knob counterclockwise (-) until completely loose.
2. Using a 5 mm hex key, remove the two bolts holding the brake pad against the frame (Figure 7).
3. Remove the bolt on the brake pad with a 3 mm hex key (Figure 8).
4. Replace the brake pad and secure it with the bolt removed in Step 3.
5. Pull up the resistance knob and slide the new brake pad into place. Secure it using the two bolts removed in Step 2.

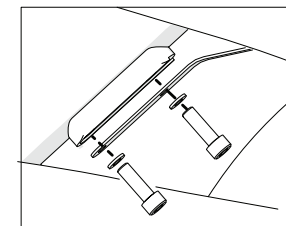

Figure 7

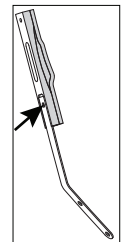

Figure 8



Spinner® Bike Line

Limited Warranty

PLEASE READ THESE WARRANTY TERMS AND CONDITIONS CAREFULLY BEFORE USING YOUR PRECOR INCORPORATED PRODUCT. BY USING THE EQUIPMENT, YOU ARE CONSENTING TO BE BOUND BY THE FOLLOWING WARRANTY TERMS AND CONDITIONS.

Limited Warranty.

Precor Incorporated ("Precor") warrants all new Precor products to be free from defects in materials and manufacture for the warranty periods set forth below. The warranty periods commence on the invoice date of the original purchase. This warranty applies only against defects discovered within the warranty period and extends only to the original purchaser of the product. Parts repaired or replaced under the terms of this warranty will be warranted for the remainder of the original warranty period only. To claim under this warranty, the buyer must notify Precor or your authorized Precor Distributor within 30 days after the date of discovery of any nonconformity and make the affected product available for inspection by Precor or its service representative. Precor's obligations under this warranty are limited as set forth below.

Warranty Periods and Coverage.

All Commercial indoor cycles manufactured and sold after January 1, 2016, subject to the terms and conditions set forth herein:

	Spinner Ride Spinner Shift	Spinner Rally Spinner Chrono
Frame	7 years	10 years
Mechanical Parts	2 years	
Labor	1 year	
Wear Items	90 days	
Console	1 year	

Limited Extended Warranty and Coverage.

To the extent the original purchaser purchases a limited extended warranty for Spinner Bike Line products as set forth in a signed Product Quote that has been accepted by Precor, then such limited extended warranty (i) shall only apply to Mechanical and Electrical parts and Product Labor, if applicable, (ii) shall commence on the invoice date of the original purchase, (iii) shall replace, and not be in addition to, the warranty periods for Mechanical and Electric parts and Product Labor set forth above (e.g., the standard warranty period and the extended warranty period shall NOT be cumulative), and (iv) shall be subject to all the terms and conditions set forth herein.

In no event shall any limited extended warranty apply to the following parts:

- Wear Items, including: Headphone Jacks, USB Connectors, Batteries, Pedals, Toe Straps, Seats, Belts, and Chains.

Conditions and Restrictions.

This warranty is valid only in accordance with the conditions set forth below:

1. The warranty applies to the Precor product only if:
 - a. it has been serviced by a Precor Authorized Service Provider and/or Precor Certified facility staff. Outside of North America, such product must be serviced by Precor office or Precor Authorized Distributors.
 - b. it remains in the possession of the original purchaser and proof of purchase is demonstrated.
 - c. it has not been subjected to accident, misuse, abuse, improper service, or non-Precor modification.
 - d. claims are made within the warranty period.
2. This warranty does not cover damage or equipment failure caused by electrical wiring not in compliance with electrical codes or Precor owner's manual specifications, or failure to provide reasonable and necessary maintenance as outlined in the owner's manual.
3. Precor is not responsible for Internet connectivity to its products. This restriction applies to services, such as those provided by an Internet service provider (ISP), and also to hardware related to Internet connectivity, such as Ethernet cabling, routers, servers and switches.
4. Precor is not responsible for the quality of television, video, audio, or other media supplied to its products. This restriction applies to services, such as those provided by a cable or satellite television provider; to signal strength and clarity; and also to hardware related to the reception and delivery of television, video, audio, and other media. Such hardware can include (but is not limited to) audio, video, and radio-frequency (RF) cabling, connectors, receivers, modulators, combiners, distribution amplifiers, splitters, and so on.
5. Precor cannot guarantee that the heart rate measurement system on its products will work for all users. Heart rate measurement accuracy varies based on a number of factors, including the user's physiology and age, the method in which the heart rate measurement system is used, external interference, and other factors that may influence heart rate acquisition.
6. Precor does not warranty the work or product of third party companies (e.g., head end systems, low voltage wiring, etc.).

7. Except in Canada, Precor does not pay labor outside the United States. Equipment limited warranty is void when equipment is installed in a country other than where sold.
8. Moving parts bolted to the structural frame are not included in the "Structural Frame" warranty (e.g., moving arms, seat and back pad assemblies, cross ramp assemblies, position adjustments, etc.)
9. In the case of commercial indoor cycle products sold into a residential (home) environment, the term of limited warranty coverage remains the same regardless of where the equipment is installed or used.

This Limited Warranty shall not apply to:

1. Software updates.
2. Software defects that do not materially and negatively affect the exercise functionality of the product under normal use conditions at the time of installation.
3. Consumable goods or cosmetic items of the product, to include all plastic or painted surfaces, the exterior of which has been damaged or defaced as a result of abuse, misuse, accident, improper service or installation, mishandling or modification in design or construction not authorized by Precor; including, without limitation, use or incorporation of any non-OEM (Original Equipment Manufacturer) replacement parts.
4. Cosmetic, structural, or functional damage (including rust, corrosion and unusual wear) caused by failure to follow the maintenance procedures described in the owner's manual.
5. Repairs performed on Precor equipment missing a serial number or with a serial tag that has been altered or defaced.
6. Service calls to correct installation of the equipment or instruct owners on how to use the equipment.
7. RFID tokens.
8. Pickup and delivery involved with repairs.
9. Any labor costs incurred beyond the applicable labor warranty period.

Disclaimer and Release.

The limited warranties provided herein are the exclusive warranties given by Precor and supersede any prior, contrary or additional representations, whether oral or written. ANY IMPLIED WARRANTIES, INCLUDING THE WARRANTY OF MERCHANTABILITY OR FITNESS FOR A PARTICULAR PURPOSE THAT APPLY TO ANY PARTS DESCRIBED ABOVE ARE LIMITED IN DURATION TO THE PERIODS OF EXPRESS WARRANTIES GIVEN ABOVE FOR THOSE SAME PARTS. PRECOR HEREBY DISCLAIMS AND EXCLUDES THOSE WARRANTIES THEREAFTER. Some jurisdictions do not allow limitations on how long an implied warranty lasts, so the above limitation may not apply to you. PRECOR ALSO HEREBY DISCLAIMS AND EXCLUDES ALL OTHER OBLIGATIONS OR LIABILITIES, EXPRESS OR IMPLIED, ARISING BY LAW OR OTHERWISE, WITH RESPECT TO ANY NONCONFORMANCE OR DEFECT IN ANY PRODUCT, INCLUDING BUT NOT LIMITED TO: (A) ANY OBLIGATION, LIABILITY, RIGHT, CLAIM OR REMEDY IN TORT, WHETHER OR NOT ARISING FROM THE NEGLIGENCE OF PRECOR OR ITS SUPPLIERS (WHETHER ACTIVE, PASSIVE OR IMPUTED); AND (B) ANY OBLIGATION, LIABILITY, RIGHT, CLAIM OR REMEDY FOR LOSS OF OR DAMAGE TO ANY EQUIPMENT. This disclaimer and release shall apply even if the express warranty set forth above fails of its essential purpose.

Exclusive Remedies.

For any product described above that fails to conform to its warranty, Precor will provide, at its sole discretion, one of the following: (1) repair; (2) replacement; or (3) refund of the purchase price. Precor Limited Warranty service may be obtained by contacting the authorized Precor office or Distributor from whom you purchased the item. Precor compensates Precor Authorized Servicers for warranty trips within their normal service area to repair commercial equipment at the customer's location. You may be charged a trip charge outside the service area. THESE SHALL BE THE SOLE AND EXCLUSIVE REMEDIES OF THE BUYER FOR ANY BREACH OF WARRANTY.

EXCLUSION OF CONSEQUENTIAL AND INCIDENTAL DAMAGES.

PRECOR AND/OR ITS SUPPLIERS SHALL HAVE NO OBLIGATION OR LIABILITY, WHETHER ARISING IN CONTRACT (INCLUDING WARRANTY), TORT (INCLUDING ACTIVE, PASSIVE, OR IMPUTED NEGLIGENCE AND STRICT LIABILITY), OR OTHERWISE, FOR DAMAGE TO THE EQUIPMENT, PROPERTY DAMAGE, LOSS OF USE, REVENUE OR PROFIT, COST OF CAPITAL, COST OF SUBSTITUTE EQUIPMENT, ADDITIONAL COSTS INCURRED BY BUYER (BY WAY OF CORRECTION OR OTHERWISE) OR ANY OTHER INCIDENTAL, SPECIAL, INDIRECT, OR CONSEQUENTIAL DAMAGES, WHETHER RESULTING FROM NONDELIVERY OR FROM THE USE, MISUSE OR INABILITY TO USE THE PRODUCT. This exclusion applies even if the above warranty fails of its essential purposes and regardless of whether such damages are sought for breach of warranty, breach of contract, negligence, or strict liability in tort or under any other legal theory. Some jurisdictions do not allow the exclusion or limitation of incidental or consequential damages, so the above limitation may not apply to you.

This warranty gives you specific legal rights, and you may also have other rights, which vary from one jurisdiction to another.

Complete this portion and keep for your records.

Purchased from:

Example: Distributor or store name.

Phone number:

Example: Distributor or store telephone number.

Product/model:

Example: Spinner Rally.

Serial number:

The serial number is found on the shipping container.

